

FLOODLIGHTS

QINA LED FL



Approximate Dimensions:

Width: 180 mm

Height: 100 mm

General Data:

Construction:

Body Die Cast Aluminum with Triple Coated Epoxy Paint and 304 Grade Stainless Brackets and Bolts

Lens Tempered Glass

*Wire Guard: 304 Stainless

IP Rating IP65

Typical

Applications:

Flood lighting Outdoor

Industrial

Wet and Corrosive Area's

Front View:

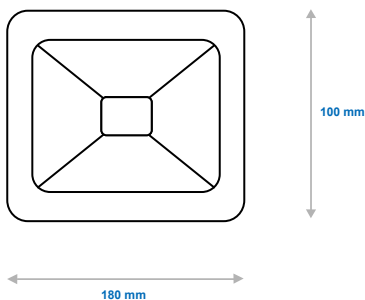

Side View:

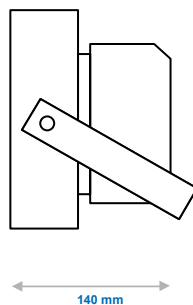

FLOODLIGHTS

QINA LED FL



Options:

- .../12VDC (12V DC - Low Voltage)
- .../230VAC (230V AC - Hi Voltage)
- .../2800K (Warm White)
- .../6500K (Day light)
- .../PIRS (Passive Infrared Motion Sensor)
- .../WGRD (Wire Guard)
- * On request only

Product Information:

Product Code	Luminaire Wattage	CCT (K)	CRI / RA	Initial Lumens (LM)	Beam Angle	H (mm)	L (mm)	W (mm)	(kg)
QIN-110	10W	See options	>80	900	120°	85	113	87	0.8
QIN-120	20W			2000		100	140	180	1.4
QIN-130	30W			3000		184	128	224	2.4

Complete your Project:

Please select the items you require and we will be in touch

Cables and Wires:

Indoor
Outdoor
General
Other
Let an ACTOM
Specialist Contact you

Lighting:

Indoor
Outdoor
General
Other
Let an ACTOM
Specialist Contact you

Transformers (Distribution):

Indoor
Outdoor
General
Other
Let an ACTOM
Specialist Contact you

Accessories:

Indoor
Outdoor
General
Other
Let an ACTOM
Specialist Contact you

Specific Information:

Address: 4 Branch Road, Germiston 1401, P.O. Box 678, Germiston 1400

For more Information on this Product Please Send us the Following

Product Information:

Product Name:

Quantity:

Project Name:

Date the Product is required:

Your Contact Information:

Name and Surname:

Company:

Email:

Phone Number:

Province:

Thank You

For having a Look at this Product

Please send this PDF back to us with all your Information

Scan the QR Code to visit our Website:

